



# CENTRIFUGAL SINGLE INLET FANS **CHMT Series**

**CHMT/4-280/115 2,2KW  
(230/400V50HZ)LG VE**



Range of single inlet direct drive centrifugal fans designed for smoke extraction in fire conditions and certified F400-120 (CE marked).

All casings are manufactured from electro-welded sheet steel protected against corrosion by grey epoxy-polyester paint coating.

All models incorporate forward curved centrifugal impellers manufactured from galvanised sheet steel.

Available, depending upon the model, with single or three phase motors in 4 or 6 poles.

## **Motors**

All motors are IP55, class H.

Electrical supply:

-Three phase 230/400V-50Hz up to 3kW.

-Three phase 400V-50Hz, for higher power motors.

(See characteristics chart).

## **Additional information**

The scroll can be orientated in 8 different positions as per the table below.

Standard supplied position: LG 270.

## **On request**

Fan supplied in RD positions.

Fan fitted with 2-speed motor.

## **+ Attributes**



### **Motor approved S1 and S2**

F400-120 certified motors approved for running continuously (S1) or for emergency operation (S2).



### **Impellers dynamically balanced**

Forward curved centrifugal impellers dynamically balanced according to ISO 1940 standard, providing vibration free operation.

**+ Acoustic characteristics**

Unfortunately an error occurred.

**+ Technical characteristics**

Unfortunately an error occurred.

**+ Orientation**

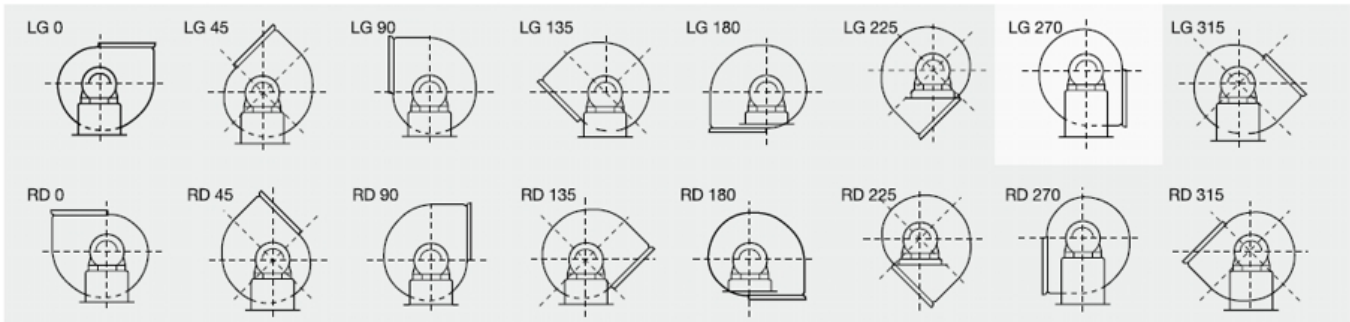

Standard position: LG 270. Special versions are supplied under request.

## + Dimensions

Unfortunately an error occurred.

11

## + Curves

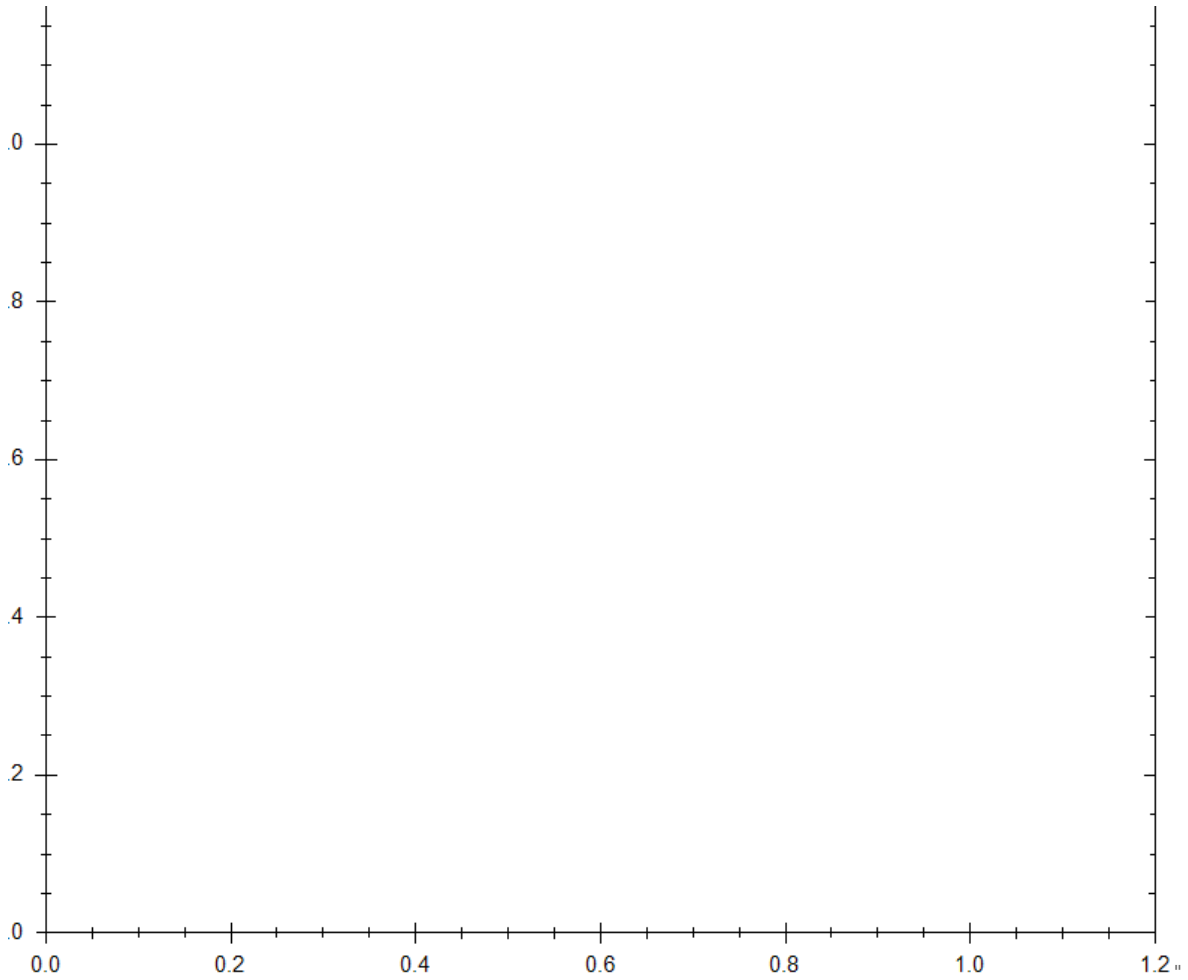

## + Mounting Accessories

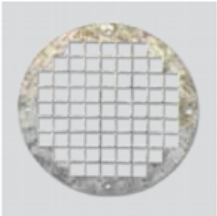

**KRJ**  
Inlet guard.

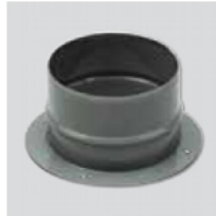

**KBA**  
Inlet mounting  
flange.

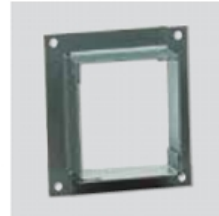

**KBD**  
Discharge  
mounting flange.



**ACOPEL F400 N**  
Circular flexible  
connector.  
Certified F400-120.



**KAD F400**  
Rectangular flexible  
connector.  
Certified F400-120.